



SPECIAL FEATURES

- Built-In Speaker
- Anti-Glare & Hard Coating Screen
- Dual Hinge Base Stand
- Easily Removable Base Stand
- VGA In 15 Pin D-Sub Interface
- Active Matrix TFT Pixel Type Display

SPECIFICATIONS

		19RTL B
Display	Screen Size	19 Inch
	Max. Resolution	1280 x 1024 @ 75Hz
	Pixel Pitch	0.294 x 0.294mm
	Brightness	300cd/m ²
	Contrast Ratio	700 : 1
	Pixel Type	Active Matrix TFT
	Viewing Angle (L/R/T/B)	170° / 170°
	Display Color	16.7 Million
	Response Time	15(Tf) - 20(Tr)ms
	Video System	NTSC / PAL
	Frequency (H)	30~81 KHz(H)
	Frequency (V)	55~75 KHz(V)
Interface	VGA In (15Pin D-Sub)	1
Audio	Built-In Speaker	Yes
Special Features	Screen	Anti-Glare & Hard Coating
Dimension	Outline Dimension (w/o Stand)	16.5" W x 14.7" H x 2.3" D
	Outline Dimension (w/ Stand)	16.5" W x 15.9" H x 2.3" D
	Net. Weight	5.9Kg (13.2lbs)
	Gross Weight	7.4Kg (16.5lbs)
Warranty	Part/Labor	1year / 1year
	MTBF (Approx.)	30,000 Hours
Regulations		UL, FCC(B), TUV / GS, CE, RRL
Power	Consumption: < On	< 35W
	Electrical Ratings	AC110 ~ 230V(50/60Hz) DC12V / 3.7A
Circumstance	Operating Temperature	10 ~ 40°C / 50 ~ 104°F
Stand Type	Base Stand	Tilt Type
	VESA Size	100mm x 100mm
Mounts	Wall	WB-05, WB-10, WB-30, WB-31
	Ceiling / Rack	CMK-01 / RMK-08

*Design and Specs are subject to change without any notice

DIMENSIONS

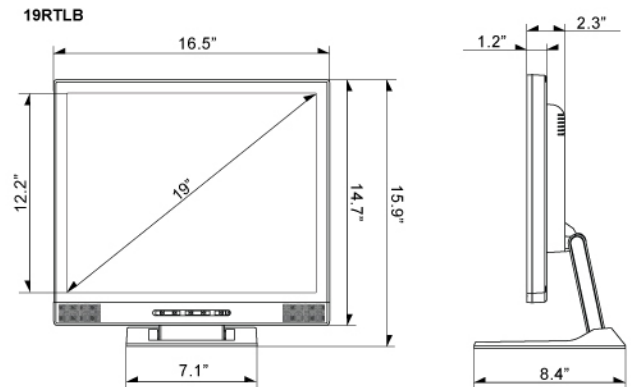

STAND CAPABILITY

The RTL B's Dual Hinge base stand can tilt 90 degree and fold as pictures describe below.

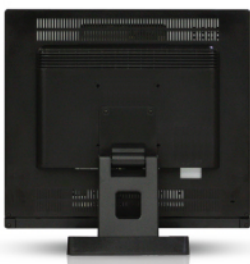

Rear View



Side View



Front View